

# HAJI TOOLS & HARDWARE

HOUSE OF STAINLESS STEEL FASTENERS

## Technical Specification of Hexagon Head Screws (Fully Threaded) as per DIN 933

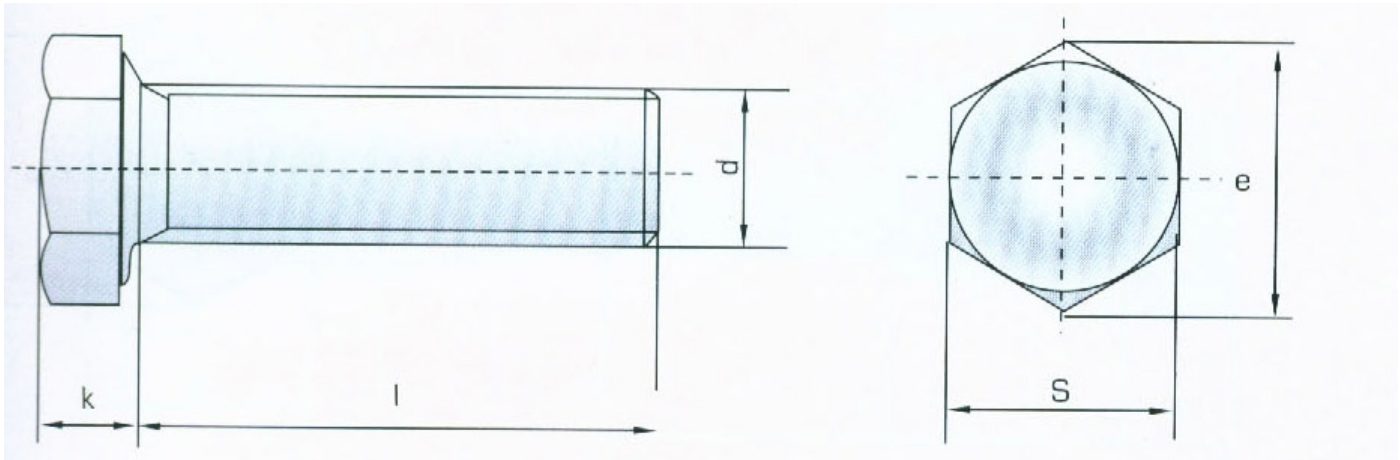

Thread Size	M3	M3.5	M4	M5	M6	M8	M10	M12	M14	M16	M18	M20
Pitch	0.5	0.6	0.7	0.8	1	1.25	1.5	1.75	2	2	2.5	2.5
e min	6.01	6.58	7.66	8.79	11.05	14.38	18.9	21.1	24.49	26.75	30.14	33.53
k min.	1.88	2.28	2.68	3.35	3.85	5.15	6.22	7.32	8.62	9.82	11.28	12.28
max	2.12	2.52	2.92	3.65	4.15	5.45	6.56	7.68	8.98	10.18	11.72	12.72
s max	5.5	6	7	8	10	13	17	19	22	24	27	30
min	5.32	5.82	6.78	7.78	9.78	12.73	16.73	18.67	21.67	23.67	26.67	29.67

# HAJI TOOLS & HARDWARE

HOUSE OF STAINLESS STEEL FASTENERS

## Technical Specification of Hexagon Head Bolts (Half Thread) as per ISO – 4014

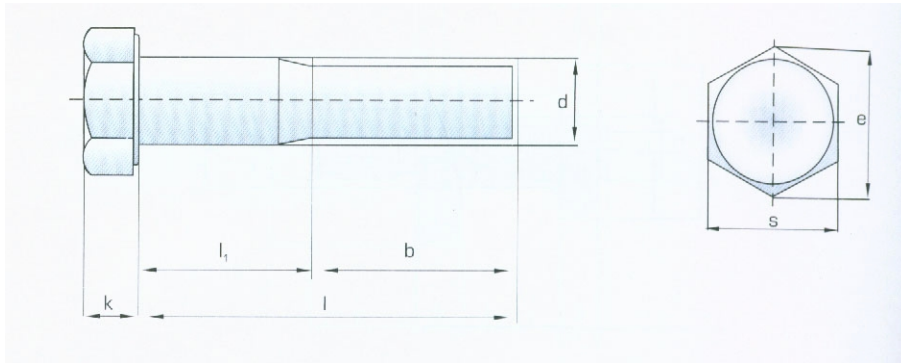

Thread	M6	M8	M10	M12	M14	M16	M18	M20
Size								
p	1	1.25	1.5	1.75	2	2	2.5	2.5
b	18	22	26	30	34	38	42	46
e min	11.05	14.38	18.9	21.1	24.49	26.75	30.14	33.53
k min.	3.85	5.15	6.22	7.32	8.62	9.82	11.28	12.28
max.	4.15	5.45	6.58	7.68	8.98	10.18	11.72	12.72
s max.	10	13	17	19	22	24	27	30
min	9.78	12.73	16.73	18.67	21.67	23.67	26.67	29.67